

MINISLIDE MSQscale measuring system

Distance measuring system integrated into the
MINISLIDE MSQ micro frictionless table

| | | |
|----------|---|-----------|
| 1 | MINISLIDE MSQscale Product Overview | 4 |
| 1.1 | Technical Data | 6 |
| 2 | MINISLIDE MSQscale Product Characteristics | 7 |
| 2.1 | High Speed and Acceleration | 7 |
| 2.2 | High Process Reliability thanks to Cage Control | 7 |
| 2.3 | Maximum Rigidity and Load Capacities | 8 |
| 2.4 | Reference and Supporting Surfaces | 8 |
| 2.5 | Running Accuracy and Parallelism of Supporting Surfaces | 8 |
| 2.6 | Tolerance of the Total Height | 9 |
| 2.7 | Push Force and Preload | 9 |
| 2.8 | Friction and Smoothness | 9 |
| 3 | MINISLIDE MSQscale Working Method and Components | 10 |
| 3.1 | Dimensional Scale and Optical Sensor | 10 |
| 3.2 | Interface Module | 12 |
| 3.3 | Lubrication | 15 |
| 4 | Options | 16 |
| 4.1 | Interface Modules | 16 |
| 4.2 | Digital Interface Module Resolution | 16 |
| 4.3 | Height Adjusted (HA) | 16 |
| 4.4 | Customer-specific Lubrication (KB) | 16 |
| 4.5 | Linearity Protocol | 16 |
| 5 | Accessories | 17 |
| 5.1 | Extensions | 17 |
| 5.2 | MINISLIDE MSQscale Counter and Position Indicator | 18 |
| 6 | Dimension Tables, Load Capacities, Weights and Moment Loads | 19 |
| 6.1 | MSQS 7 | 19 |
| 6.2 | MSQS 9 | 20 |
| 6.3 | MSQS 12 | 21 |
| 6.4 | MSQS 15 | 22 |
| 7 | Load Carrying Capacity and Service Life | 23 |
| 7.1 | Principles | 23 |
| 7.2 | Calculation of Service Life L in Accordance with the DIN ISO Standard | 24 |
| 8 | Ordering Information | 26 |

1 MINISLIDE MSQscale Product Overview

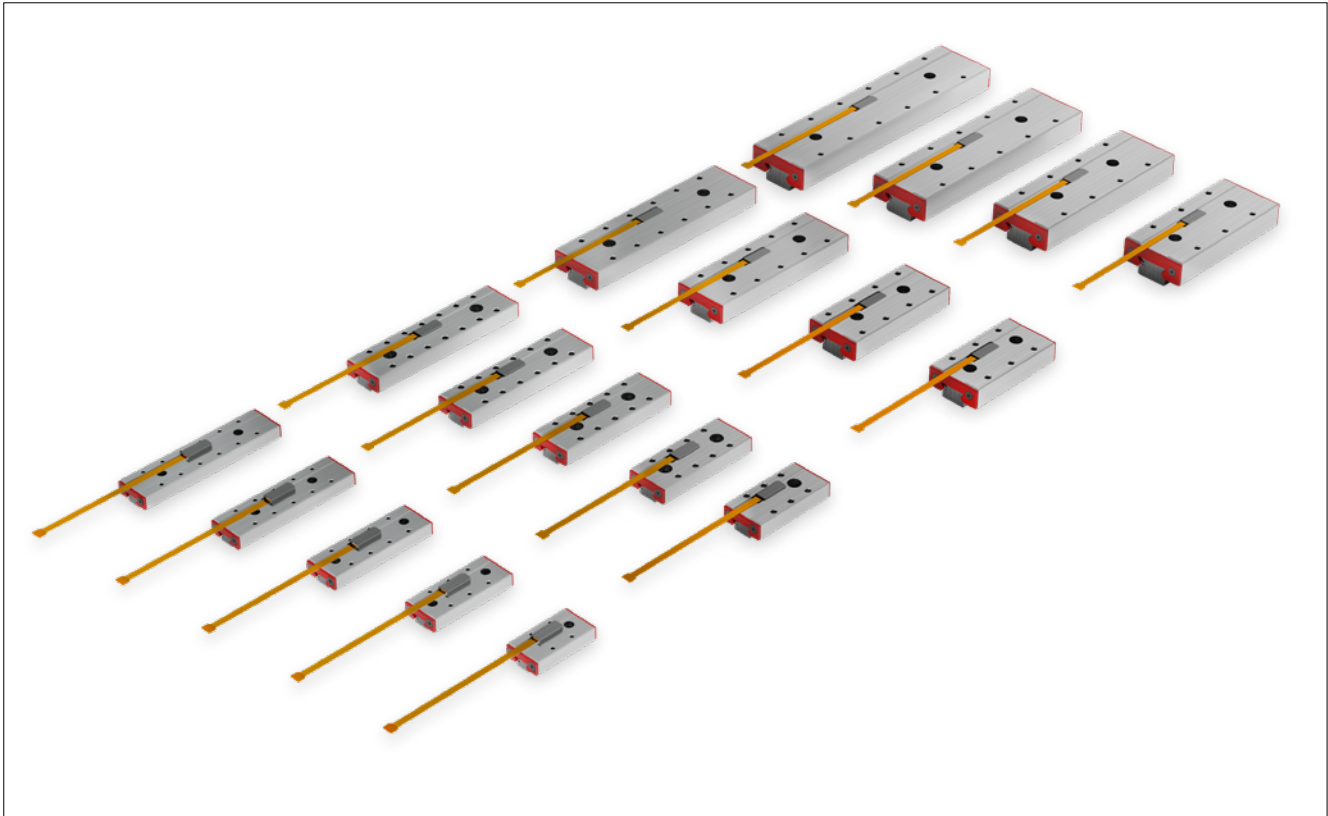

Product range of MINISLIDE MSQscale

Demanding applications demand special guideways. This extraordinary innovation combines guiding and measuring functions in a highly integrated design. MINISLIDE MSQscale makes the most compact applications possible and significantly simplifies assembly and installation. Thus, the MINISLIDE MSQscale is an extremely economical solution that meets stringent technical requirements.

The MINISLIDE MSQscale is based on our MINISLIDE MSQ guideways. MINISLIDE MSQ embodies the latest generation of miniature guideways for very demanding applications. They are extremely robust and prove themselves in every application requiring low friction, precise motion.

The guideway has a highly precise, optical, incremental measuring system. The dimensional scale and sensor are perfectly integrated into the guideway.

The MINISLIDE MSQscale range includes sizes 7, 9, 12 and 15 with travel distances from 20 to 102 mm.

1 MINISLIDE MSQscale Product Overview

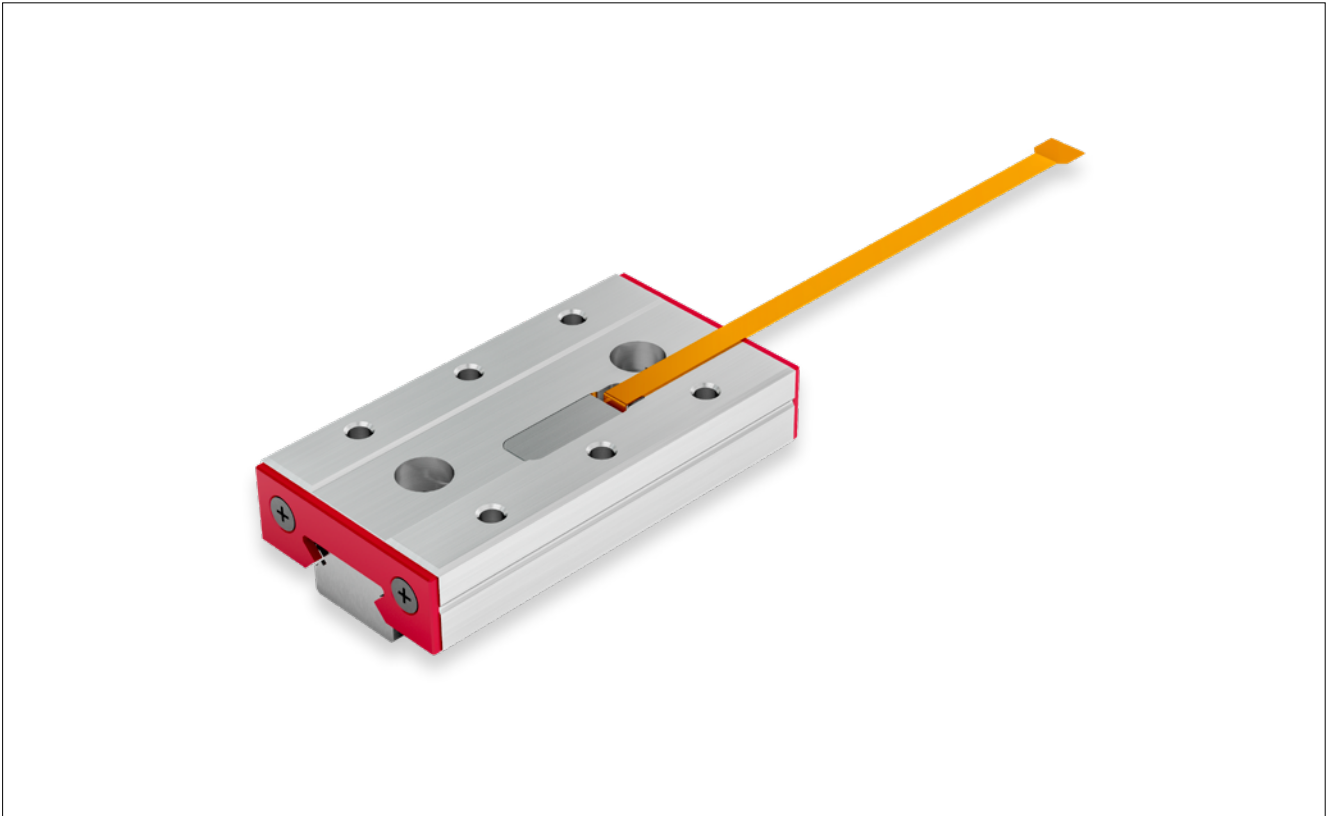

MINISLIDE MSQscale

- | | |
|---|--|
| Highly integrated, compact design | <ul style="list-style-type: none"> • The sensor is perfectly integrated into the carriage and sealed • The dimensional scale is marked directly on the guideway |
| Minimal design planning | <ul style="list-style-type: none"> • Extra space for a separate distance measuring system is not required • More compact designs can be implemented |
| Quick and easy mounting | <ul style="list-style-type: none"> • The MSQscale is ready to install upon delivery • No need for additional components and special mounting (as would be required for a glass scale, for example) • No need to adjust the read head separately • No need to align or mount the measuring scale |
| Consistently high level of accuracy | <ul style="list-style-type: none"> • Very smooth running with no rolling element pulsation • The position measurement is performed directly at the point of friction This simplifies the controlling of micromovements and dynamic motions • No hysteresis or positioning errors compared to recirculating ball screws with rotary encoders • Measurement is carried out directly during the work process This reduces Abbe errors • High Repeatability • Immune to vibration and shock as a single assembly |
| High level of reliability and long service life | <ul style="list-style-type: none"> • The MSQscale is based on the successful MINISLIDE MSQ design and the proven measuring technology of the MINISCALE Plus |

1 MINISLIDE MSQscale Product Overview

1.1 Technical Data

| | |
|---|--|
| Max. acceleration | 300 m/s ² |
| Max. speed | 3 m/s |
| Preload | Zero backlash |
| Accuracy of guideway | See chapter 2.5 |
| Areas of application: | |
| Temperature range ⁽¹⁾ | -40 °C to +80 °C (-40 °F to +176 °F) |
| Humidity | 10 % – 70 % (non-condensing) |
| Vacuum compatibility ⁽²⁾ | High vacuum (10 ⁻⁷ mbar) |
| Cleanroom compatibility | Cleanroom class ISO 7 and ISO 6 (in accordance with ISO 14644-1) |
| Materials: | |
| Guideways, carriages, balls | Stainless steel, through-hardened |
| Cage and pinion | PEEK |
| End pieces | PEEK |
| Resolution | TTL output 0.1 µm ⁽³⁾ (optional: 1 µm / 10 µm) |
| Accuracy of measuring system ⁽⁴⁾ | +/- 3 µm |
| Repeatability ⁽⁴⁾ | Unidirectional +/- 0.1 µm Bidirectional +/- 0.2 µm (with resolution of 0,1 µm) |
| Dimensional scale | Pitch 100 µm Coefficient of expansion 11.7 x 10 ⁻⁶ K ⁻¹ |
| Supply voltage | 5 V DC +/- 5 % |
| Current consumption | 60 mA (analog) / 70 mA (digital) |
| Output signal | Analog: 1 V _{ss} Digital: TTL in accordance with RS 422 standard |
| Source format | Analog: Differential sin/cos analog signals with reference pulse or Digital: Differential, interpolated digital signals (A, B, R) The reference signal is synchronised with the incremental signals |

⁽¹⁾ The standard lubrication covers a temperature range from -20° C to +80° C. Lubricants for other temperatures are available upon request from SCHNEEBERGER (see chapter 4.4).

⁽²⁾ The suitability for a vacuum depends on the materials used. In order to use MSQscale in a vacuum, the fastening screws and front plates must be removed. There are also restrictions on the use of sensor accessories. Use in a vacuum requires a special lubricant available from SCHNEEBERGER. Please contact your SCHNEEBERGER representative for details on vacuum application.

⁽³⁾ Note the high signal frequencies at high resolution and high speed.

⁽⁴⁾ The values apply at 20°C (68°F)

2 MINISLIDE MSQscale Product Characteristics

The range includes rail widths of 7, 9, 12 and 15 mm, that are available, depending on type, in four or five different lengths and strokes.

| MSQscale 7 | MSQS 7-30.20 | MSQS 7-40.28 | MSQS 7-50.36 | MSQS 7-60.50 | MSQS 7-70.58 |
|---------------------|--------------|--------------|--------------|--------------|--------------|
| System length in mm | 30 | 40 | 50 | 60 | 70 |
| Max. stroke in mm | 20 | 28 | 36 | 50 | 58 |

| MSQscale 9 | MSQS 9-40.34 | MSQS 9-50.42 | MSQS 9-60.50 | MSQS 9-70.58 | MSQS 9-80.66 |
|---------------------|--------------|--------------|--------------|--------------|--------------|
| System length in mm | 40 | 50 | 60 | 70 | 80 |
| Max. stroke in mm | 34 | 42 | 50 | 58 | 66 |

| MSQscale 12 | MSQS 12-50.45 | MSQS 12-60.48 | MSQS 12-80.63 | MSQS 12-100.70 |
|---------------------|---------------|---------------|---------------|----------------|
| System length in mm | 50 | 60 | 80 | 100 |
| Max. stroke in mm | 45 | 48 | 63 | 70 |

| MSQscale 15 | MSQS 15-70.66 | MSQS 15-90.70 | MSQS 15-110.96 | MSQS 15-130.102 |
|---------------------|---------------|---------------|----------------|-----------------|
| System length in mm | 70 | 90 | 110 | 130 |
| Max. stroke in mm | 66 | 70 | 96 | 102 |

2.1 High Speed and Acceleration

High-acceleration applications demand well thought-out solutions. The unique MINISLIDE MSQscale design with integrated cage control fulfills the requirements of the most advanced drive technologies and enables speeds up to 3 m/s and an acceleration of up to 300 m/s².

2.2 High Process Reliability thanks to Cage Control

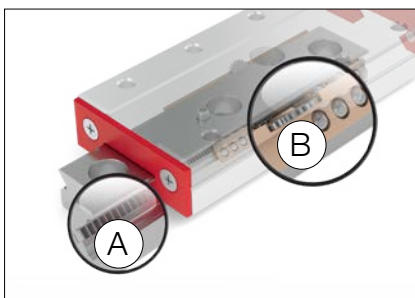

The robust cage control of MINISLIDE MSQscale

A gear rack pinion on carriage and guideway

B cage with pinion

In applications without cage control a cage is free to move along the longitudinal axis on every linear guideway. The cage generally moves out of the center position as a result of uneven weight distribution, high acceleration, vertical installation or temperature differences. This so-called cage creep compromises the efficiency of every application, since the cage must be centered regularly using corrective strokes at the expense of energy.

MINISLIDE MSQscale products are fitted with a well-engineered, robust cage control system that eliminates cage creep. The gear rack pinion of the control system is directly integrated into the carriages and guideways. The cages and pinions are made from high-quality plastic.

The compact, robust design as well as the minimum of integrated components ensure the highest strength in every commercial situation.

A mechanical limited stroke protects the cage control mechanism and makes installation and maintenance easy (this must not be used during operation as a means to limit stroke).

2 MINISLIDE MSQscale Product Characteristics

2.3 Maximum Rigidity and Load Capacities

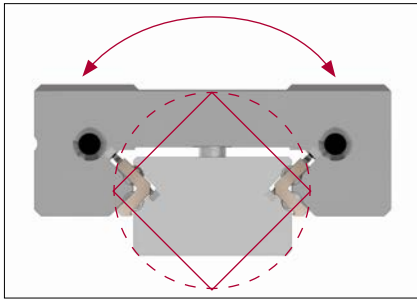

Arrangement of MINISLIDE MSQscale with four circular arc profile tracks in an O shape

MINISLIDE MSQ products have four tracks with a circular arc profile. Their arrangement in the shape of an O ensures large inner spacings. In combination with the tracks offset by 90 degrees, a high level of evenly distributed force from all directions is achieved, as well as torque rigidity.

MINISLIDE products are preloaded with zero backlash. Combined with the high number of rolling elements, a high level of system rigidity and therefore the highest precision are guaranteed.

2.4 Reference and Supporting Surfaces

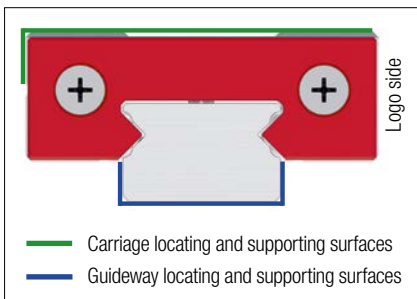

The locating and supporting surfaces of carriages and guideways are designated as follows. The reference side of the carriage is opposite the carriage side with the company logo / type designation. The guideway can be located on both sides.

2.5 Running Accuracy and Parallelism of Supporting Surfaces

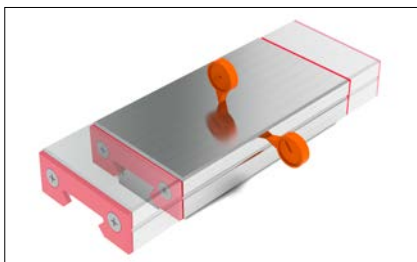

Straightness of the stroke

The tolerance for the straightness of the stroke depends on the length of the guideway. The following table shows the corresponding maximum values. The measurements are taken in an unloaded state on a flat surface.

| System length L | Straightness of the stroke (horizontally and vertically) |
|-----------------|--|
| 30 mm | 3 μm |
| 40 - 80 mm | 4 μm |
| 90 - 130 mm | 5 μm |

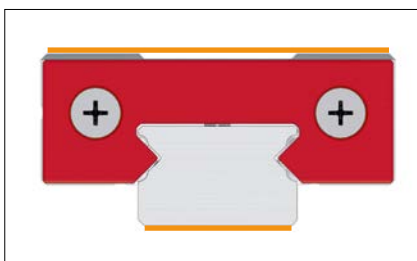

Parallelism of supporting surfaces

| System length L | Parallelism of the supporting surfaces (frictionless table in the center position) |
|-----------------|--|
| 30 mm | 12 μm |
| 40 - 80 mm | 15 μm |
| 90 - 130 mm | 18 μm |

2 MINISLIDE MSQscale Product Characteristics

2.6 Tolerance of the Total Height

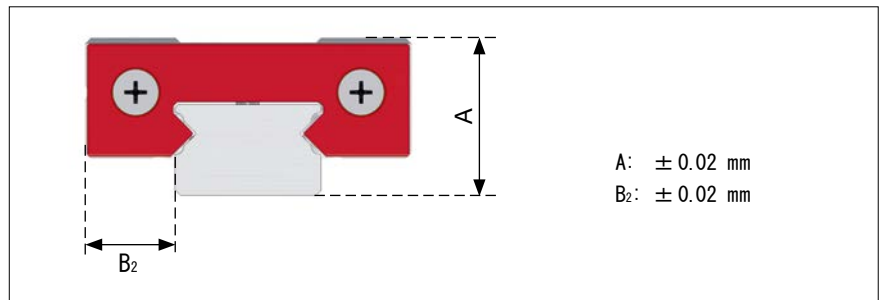

Tolerance of the total height

2.7 Push Force and Preload

The push force is influenced by the preload and the lubricant used. MINISLIDE MSQscale guideways are delivered with zero backlash and slightly preloaded as standard.

2.8 Friction and Smoothness

SCHNEEBERGER places high value on smoothness during manufacturing. The accuracy of the surfaces and materials is of the highest priority. This also applies with respect to the rolling elements used, which must satisfy the most stringent quality demands. Under normal operating conditions a coefficient of friction of 0.003 can be assumed.

3 MINISLIDE MSQscale Working Method and Components

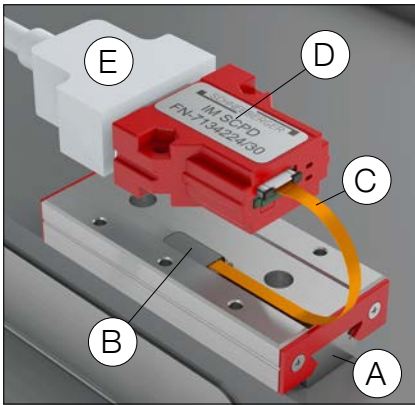

Components of MINISLIDE MSQscale

The MINISLIDE MSQscale is an optical, incremental measuring system made up of the MINISLIDE MSQ micro frictionless table and the following additional components:

- A Dimensional scale on the guide rail
- B Optical sensor integrated into the carriage
- C Flexible sensor print (must not be exposed to dynamic loads)
- D Interface module

The control cable E must be supplied by the customer and must be a flexible cable where necessary.

There are various structural types of interface modules available. These are described in section 3.2.

With a flexible flat cable (Flat Flex Cable, abbreviated: FFC), which is inserted between the flexible sensor print and the interface module, the interface module can be positioned flexibly. The FFC cables are suitable for dynamic loads. (You can find more information about accessories in section 5)

3.1 Dimensional Scale and Optical Sensor

The high-precision dimensional scale is part of the hardened guideway's surface with a scale increment of 100 μm . Two LEDs in the sensor illuminate the dimensional scale. Light-dark fields form because of the illumination of the various structured areas on the dimensional scale. These optical signals are detected by the sensor and converted into electrical signals. The raw signals supplied by the sensor are processed by the interface module.

The level of illumination provided by the LEDs is actively controlled. This can counteract the aging of the system and impurities on the dimensional scale are also compensated for.

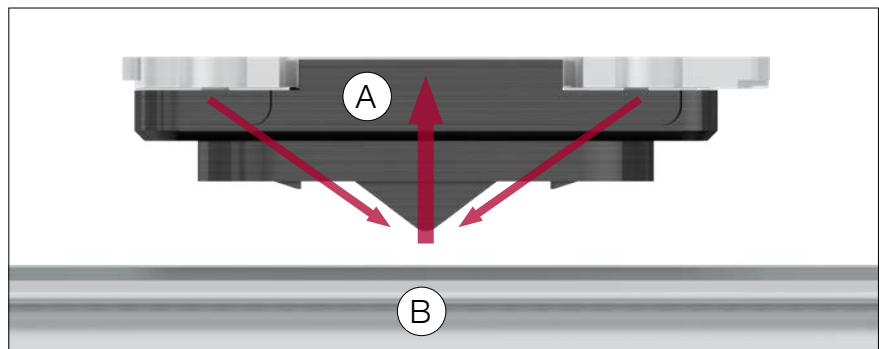

Sensor principle

A Sensor

B Guideway with dimensional scale

3 MINISLIDE MSQscale Working Method and Components

3.1.1. Reference Marks

Incremental measuring systems cannot determine the exact position when switched on. For this reason the reference track is added alongside the incremental track. One or multiple reference points can be marked on the reference track.

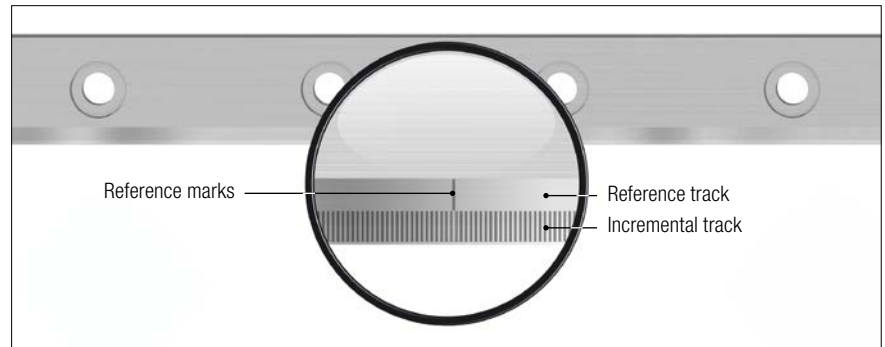

Guideway with dimensional scale

Standard version

The following reference positions are defined as standard:

- All sizes of the MSQS 7, size MSQS 9-50.42 and MSQS 9-60.50: within 4 mm of rail center point

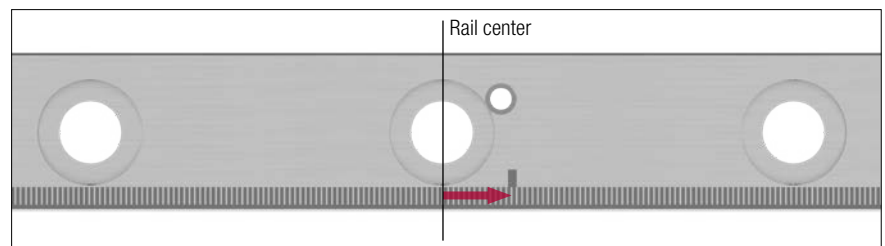

Position of the reference mark at all sizes of MSQS7, at size MSQS9-50.42 and MSQS9-60.5

- Other sizes: in the rail center

Special versions

Any number of reference marks can be chosen at any position along the reference track. It is necessary for the reference marks to be synchronised with the dimensional scale. Specifically this means that the reference marks can only be placed in multiples of 0.1 mm, since the pitch of the dimensional scale is 0.1 mm.

A minimum distance of 1.5 mm between the reference marks should be maintained. Additionally, the distance between the end of the incremental track and the reference mark must be at least 2 mm.

Restrictions:

- The attachment holes on guideways of type MSQS7 and MSQS9 are located on the reference track. The reference marks must therefore be BETWEEN the attachment holes for both of these sizes.
- When specifying the reference mark(s), ensure they can be seen by the carriage's sensor.

3 MINISLIDE MSQscale Working Method and Components

3.2 Interface Module

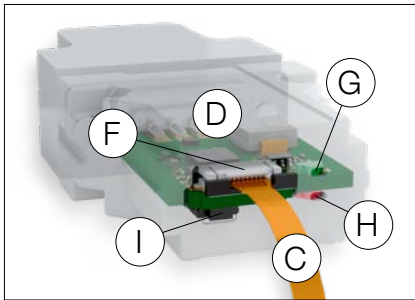

Components of the interface module

The raw signals are processed by the interface module and converted to standard output signals. Analog or digital interface modules are available.

Ensure the ZIF connector F is accessible and the LED displays (G and H) on the interface module are clearly visible. Unlike the analog interface, the digital interface includes a compensation key I, which must also be accessible.

- C Flexible Sensor Print
- D Electronics (in various structural types)
- F ZIF connector
- G Green LED (operating voltage)
- H Red LED (error indicator)
- I Compensation key (only on digital interface module)

The interface modules are available in the following structural types:



With housing
With D-Sub 9 connector

Order designation: MG
(Standard)

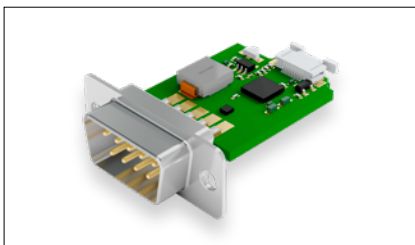
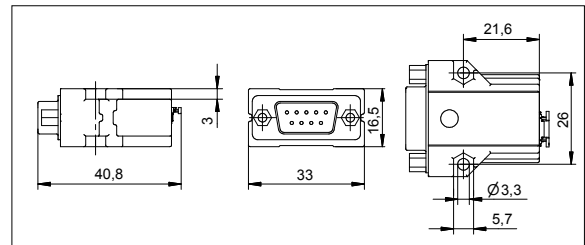

Without housing
With D-Sub 9 connector

Order designation: OG

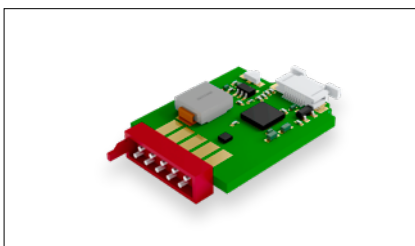
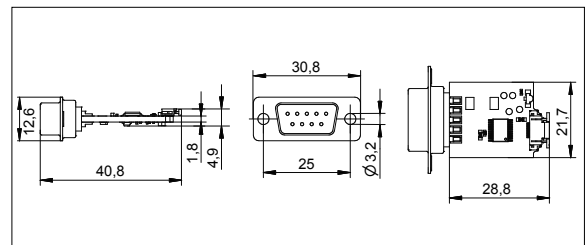

Without housing
With Micro Match
connector
(for plug-in assembly on
an electronics board)

Order designation: MM

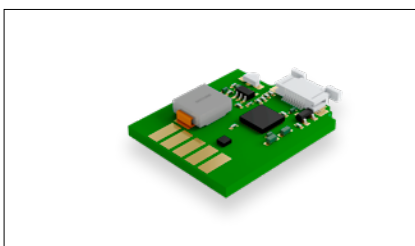
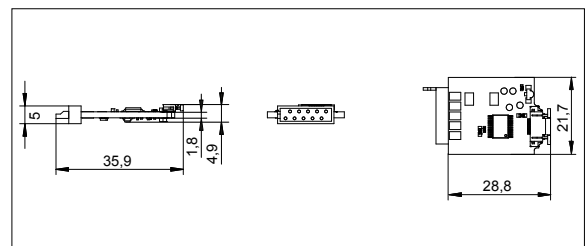

Without housing
Without connector
With solder terminals

Order designation: NL

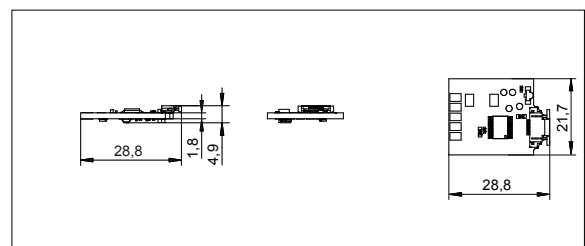

For customers with expertise in electronics, it is also possible to assemble their own digital interface module and integrate it into their own electronics, in consultation with SCHNEEBERGER.

Order designation: KI

3 MINISLIDE MSQscale Working Method and Components

3.2.1. Signal Processing

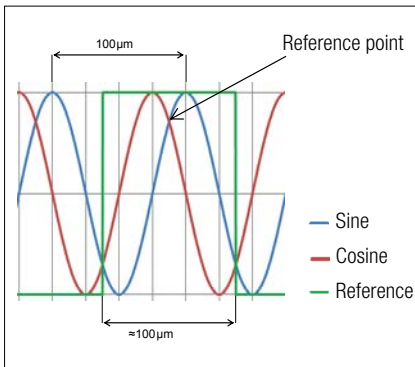

Differential, analog sin/cos signals with reference pulse

Analog output format:

Differential, sin/cos analog signals with reference pulse 1 Vpp

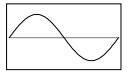

The incremental signals sine and cosine are shifted 90° and correlated with the markings on the encoded scale. An electrical signal period (360°) corresponds precisely to the scale increment of the dimensional scale, which is 100 µm.

The sine signal either lags behind the cosine signal or occurs before it, depending on the direction of movement.

The reference pulse width corresponds to about one sine signal period.

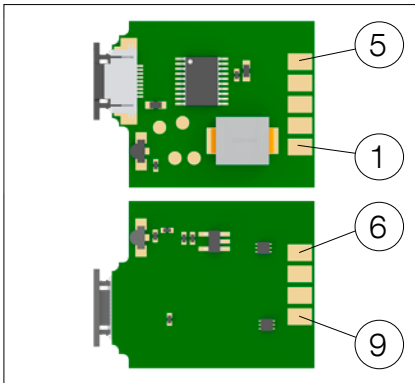
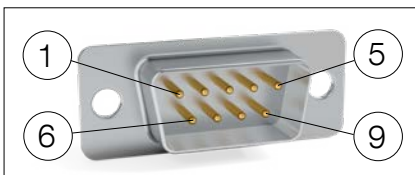

Analog interface module pin connections (1Vpp)

Male 9-pin D-Sub connector or solder terminals:

| Pin | Signal | Description |
|-----|---------|----------------------------|
| 1 | Ua1 - | Quadrature signal |
| 2 | 0V | Ground |
| 3 | Ua2 - | Quadrature signal |
| 4 | ERR NOT | Error signal (Low = Error) |
| 5 | Ua0 - | Reference signal |
| 6 | Ua1 + | Quadrature signal |
| 7 | + 5V DC | Supply voltage |
| 8 | Ua2 + | Quadrature signal |
| 9 | Ua0 + | Reference signal |

Image 1: Pin connections of D-Sub 9 connector at the interface module

Image 2: Pin connections at the interface module with solder terminals

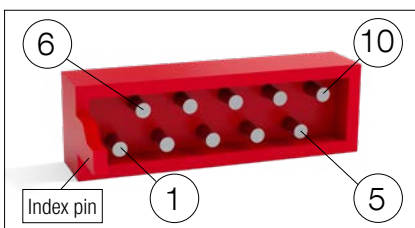

Pin connections of Micro Match connector at the interface module

Male 10-pin Micro Match connector:

| Pin | Signal | Description |
|-----|---------|----------------------------|
| 1 | nc | |
| 2 | Ua1 + | Quadrature signal |
| 3 | + 5V DC | Supply voltage |
| 4 | Ua2 + | Quadrature signal |
| 5 | Ua0 + | Reference signal |
| 6 | Ua1 - | Quadrature signal |
| 7 | 0V | Ground |
| 8 | Ua2 - | Quadrature signal |
| 9 | ERR NOT | Error signal (Low = Error) |
| 10 | Ua0 - | Reference signal |

3 MINISLIDE MSQscale Working Method and Components

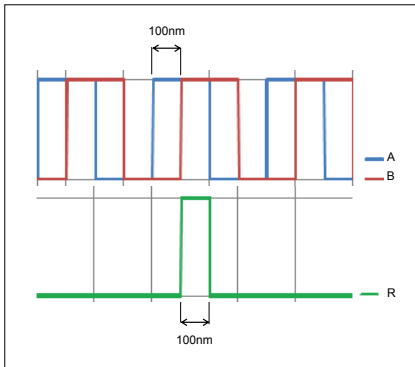

Differential, digital signals with reference pulse

Digital output format:

Differentially interpolated digital signals with reference pulse (A, B, R) TTL signal (RS422).

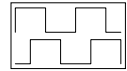

The digital interface module both processes the raw signal and interpolates the processed analog signal. The interpolation achieves a resolution of 100 nm.

The digital signal waveform consists of an A and B signal. The spacing between the two edges of signals A and B correspond exactly to a distance of 100 nm. The 100 µm increments of the encoder scale are consequently divided into 1000 sections of 100 nm by means of interpolation. The A signal either lags behind the B signal or occurs before it, depending on the direction of movement.

The reference pulse is as wide as the spacing between the two signal edges of signals A and B (as wide as one resolution).

The edges of the incremental and reference signals are synchronised.

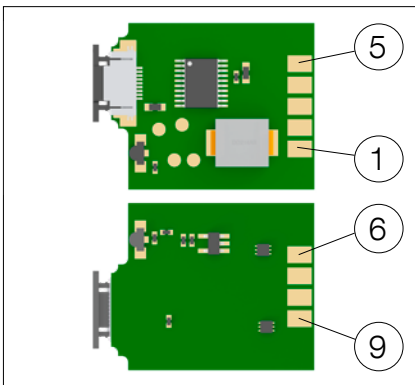
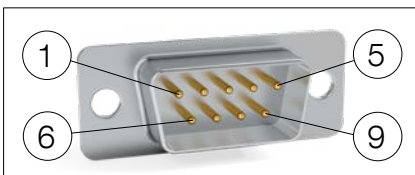

Digital interface module pin connections (TTL)

Male 9-pin D-Sub connector or solder terminals:

| Pin | Signal | Description |
|-----|---------|----------------------------|
| 1 | A - | Quadrature signal |
| 2 | 0V | Ground |
| 3 | B - | Quadrature signal |
| 4 | ERR NOT | Error signal (Low = Error) |
| 5 | R - | Reference signal |
| 6 | A + | Quadrature signal |
| 7 | + 5V DC | Supply voltage |
| 8 | B + | Quadrature signal |
| 9 | R + | Reference signal |

Image 1: Pin connections of D-Sub 9 connector at the interface module

Image 2: Pin connections at the interface module with solder terminals

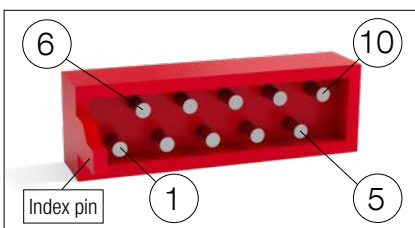

Pin connections of Micro Match connector at the interface module

Male 10-pin Micro Match connector:

| Pin | Signal | Description |
|-----|---------|----------------------------|
| 1 | nc | |
| 2 | A + | Quadrature signal |
| 3 | + 5V DC | Supply voltage |
| 4 | B + | Quadrature signal |
| 5 | R + | Reference signal |
| 6 | A - | Quadrature signal |
| 7 | 0V | Ground |
| 8 | B - | Quadrature signal |
| 9 | ERR NOT | Error signal (Low = Error) |
| 10 | R - | Reference signal |

3 MINISLIDE MSQscale Working Method and Components

3.3 Lubrication

Lubrication is a design element and must therefore be defined during the development phase of a machine or application.

Standard lubrication for MINISLIDE MSQscale is Klüber Microlube GL 262. This grease has an ideal lubrication effect in the boundary friction area and is suitable for normal and short stroke applications.

Special lubricants are used for specific purposes. For example lubricants for use in vacuums, cleanrooms, for high or low temperatures, for high speeds or high-frequency strokes. SCHNEEBERGER can deliver the guideways with the appropriate lubricant for any of these areas of application.

3.3.1. MINISLIDE MSQscale Initial Lubrication

MINISLIDE MSQscale products are lubricated with Klüber Microlube GL 262 at the factory. The systems are delivered ready-to-install. There is no need for an additional initial lubrication.

3.3.2. MINISLIDE Subsequent Lubrication Intervals

The subsequent lubrication interval depends on different influencing variables, e.g. load, working environment, speed, etc. and can therefore not be calculated. The lubrication area should therefore be monitored over a longer period.

The initial factory lubrication can, depending on the operating conditions, suffice for years.

For relubrication, use the original grease only. Keep lubricant quantities low. Over-lubrication can cause failure of the optical sensor.

Further information about lubrication is available in the MINISLIDE MSQscale mounting instructions.



4 Options

4.1 Interface Modules

The interface modules are available in the structural types described in section 3.2.

4.2 Digital Interface Module Resolution

The standard resolution of the digital interface module is 0.1 μm . Resolutions of 1 μm or 10 μm can be supplied as an option.

4.3 Height Adjusted (HA)

The standard height of the MSQscale is $\pm 20 \mu\text{m}$. This tolerance can be too large for certain configurations, for example, when the carriage spacing L_b is smaller than the carriage length L . In such cases, the height tolerances can be reduced on a customer-specific basis down to $\pm 3 \mu\text{m}$.

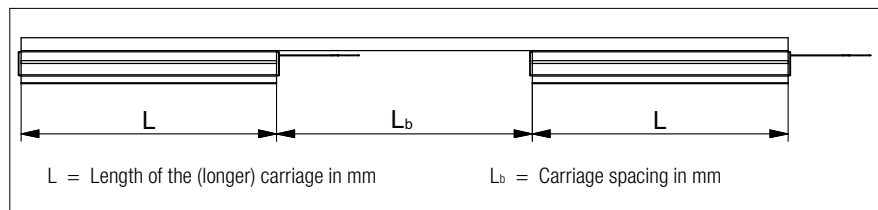

4.4 Customer-specific Lubrication (KB)

Special lubricants are used for specific applications. For example, lubricants for use in vacuums, cleanrooms, the food industry, high or low temperatures, high speeds and high-frequency strokes. SCHNEEBERGER can supply the MSQscale with application specific lubrication.

Further tested lubricants:

- | | |
|---------------------------------|------------------------|
| • High speed / Low Temperatures | Klüber Isoflex NBU 15 |
| • Clean room | Klübersynth BEM 34-32 |
| • Vacuum | Castrol Braycote 600EF |
| • Food | Klübersynth UH1 14-31 |

4.5 Linearity Protocol

For every system, a linearity protocol of the dimensional scale is created. The protocol can be included with each shipment if requested. In order to compensate for linearity deviations in the customer's own application, the protocol can also be requested in an electronic format.

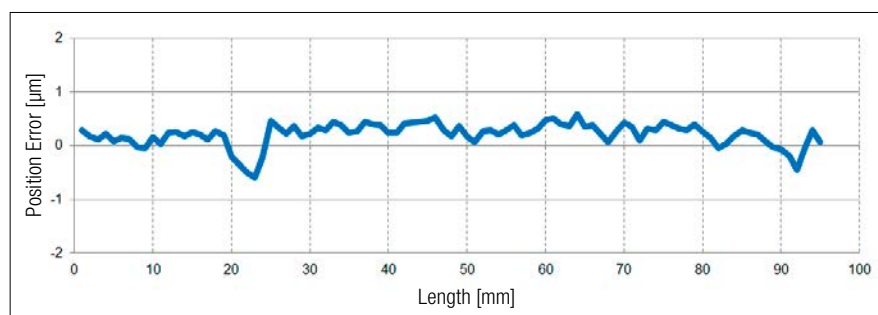

Graphic of the linearity protocol

5 Accessories

5.1 Extensions

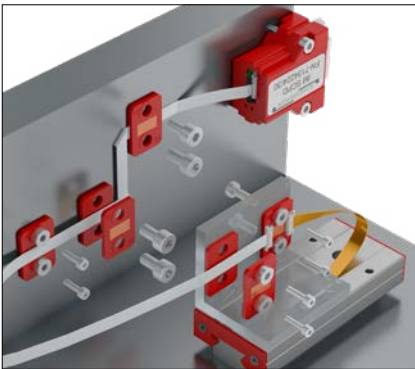

Installation example of MINISLIDE MSQscale with FFC extension



FFC cable with adapter

Wherever the interface module cannot be mounted directly at the sensor, the extension kit can be used. A flexible flat cable (Flat Flex Cable, abbreviated: FFC) is used between the sensor print and the interface module.

This offers the following benefits:

- By moving the interface module, the mass of the moving system can be reduced by moving the interface module to a non-moving location.
- The shielded FFC cable included in the extension set is also designed to be dynamically loaded. The minimum recommended bending radius is 10 mm. In contrast, the flexible sensor print can only be installed statically.
- The FFC cable provides a low push force. This can be a benefit wherever a cable that can be used in a cable carrier is too rigid.
- The FFC cable can also be folded once during installation.

FFC cables are available in three lengths: 250 mm, 400 mm and 600 mm. An adapter board is delivered with the FFC extension cable.

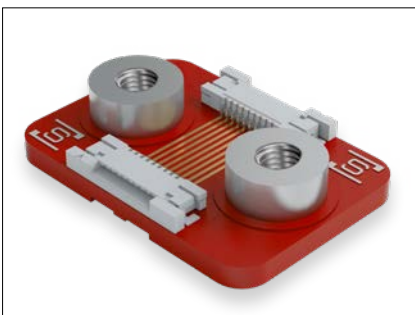

Adapter

It is used for the electrical connection between the sensor print and the extension cable. Two ZIF connectors are available on the adapter for this purpose.

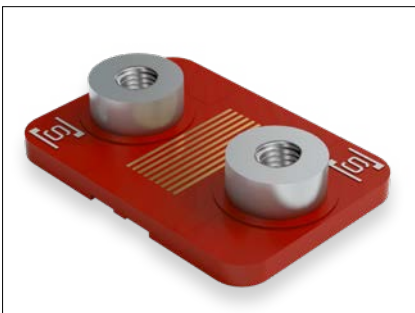
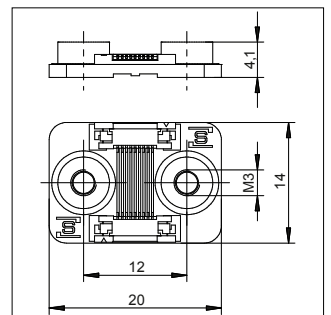

Clamp plate

Can be used for stress relief or to guide the FFC cable. Two M3 spacer sleeves are installed on the board.

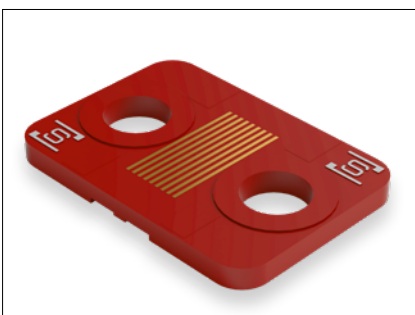
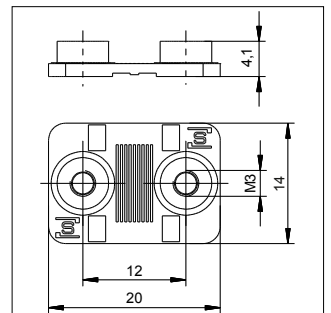

Base plate

Can be used as a base or for clamping the cable.

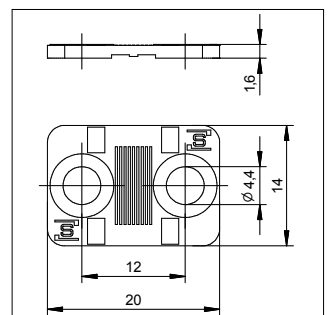

5 Accessories

5.2 MINISLIDE MSQscale Counter and Position Indicator

For simple applications, experimental or prototype setups, we recommend the USB counters from Heilig & Schwab GmbH & Co. KG. The following counters can be ordered directly from Heilig & Schwab GmbH & Co. KG (www.heilig-schwab.de).



1-axis USB Counter

5.2.1. 1-axis USB Counter

The USB counter allows a MINISCALE PLUS or similar incremental encoder with TTL, 1 Vpp, or 11 μ Ass signal output to be connected directly to a computer using a USB interface.

With the included driver software, the USB counter can be quickly and easily integrated into your application.



3-axis USB Counter

5.2.2. 3-axis USB Counter

The USB counter allows three MINISCALE PLUS or similar incremental encoders with TTL, or 1 Vpp signal output to be connected directly to a computer using a USB interface. Every counter input additionally has a latch signal input at its disposal.

With the included driver software, the USB counter can be quickly and easily integrated into your application.

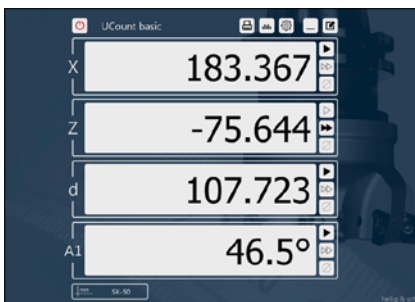

Digital display program "UCount basic"

5.2.3. "UCount basic" Digital Display Program

UCount basic is a digital display program for the evaluation of linear and angle sensors, which are connected to a computer (PC, laptop or tablet) via USB counters from Heilig & Schwab GmbH & Co. KG. Alternatively, the counters can also be connected to the computer via WLAN.

- Simple operation and clear presentation of all functions
- Meter display of up to 9 signal inputs
- Meter stop function
- Audible meter monitoring (threshold value)
- Calculation functions (addition, subtraction)
- Measuring functions (spacing, angle, included angle, radius)
- Correction function (linear correction, step-by-step (SBS) correction, parallelism correction)
- Reference point administration
- Expandable based on customer preference

System requirements:

- PC, laptop or tablet
- Windows Operating System, 32 or 64-bit version
- USB or WLAN interface

6 Dimension Tables, Load Capacities, Weights and Moment Loads

6.1 MSQS 7

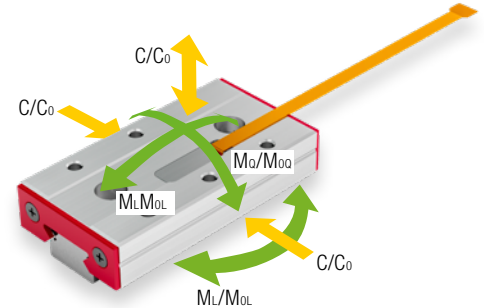
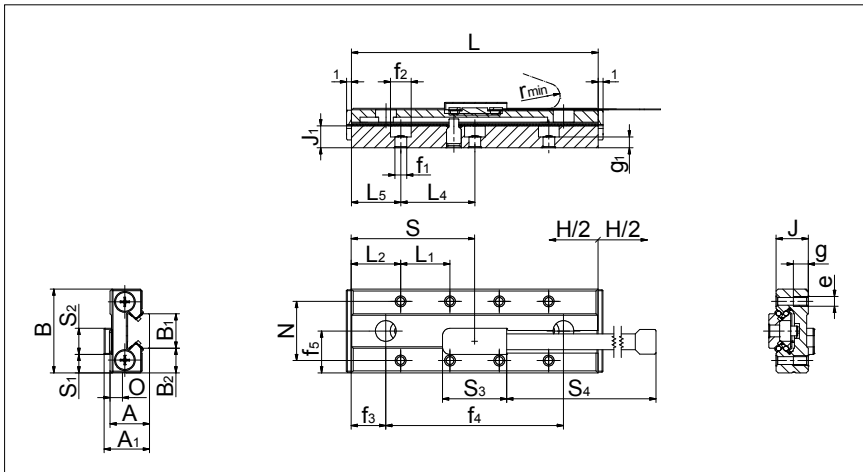

| Name | | Sizes | | | | | |
|-------------------|----------------------------|---|--------------|--------------|--------------|--------------|------|
| | | MSQS 7-30.20 | MSQS 7-40.28 | MSQS 7-50.36 | MSQS 7-60.50 | MSQS 7-70.58 | |
| Dimensions (mm) | A | System height | 8 | 8 | 8 | 8 | 8 |
| | A ₁ | System height with sensor | 9.2 | 9.2 | 9.2 | 9.2 | 9.2 |
| | B | System width | 17 | 17 | 17 | 17 | 17 |
| | B ₁ | Rail width | 7 | 7 | 7 | 7 | 7 |
| | B ₂ | Distance between locating surfaces | 5 | 5 | 5 | 5 | 5 |
| | J | Carriage height | 6.5 | 6.5 | 6.5 | 6.5 | 6.5 |
| | J ₁ | Rail height | 4.5 | 4.5 | 4.5 | 4.5 | 4.5 |
| | H | Stroke | 20 | 28 | 36 | 50 | 58 |
| | L | System length | 30 | 40 | 50 | 60 | 70 |
| | L ₁ | Attachment hole spacing | 10 | 10 | 10 | 10 | 10 |
| | L ₂ | Attachment hole start/end spacing | 10 | 10 | 10 | 10 | 10 |
| | L ₄ | Attachment hole spacing | 15 | 15 | 15 | 15 | 15 |
| | L ₅ | Attachment hole start/end spacing | 7.5 | 5 | 10 | 7.5 | 5 |
| | N | Lateral attachment hole spacing | 12 | 12 | 12 | 12 | 12 |
| | e | Thread | M2 | M2 | M2 | M2 | M2 |
| | f ₁ | Attachment hole diameter | 2.4 | 2.4 | 2.4 | 2.4 | 2.4 |
| | f ₂ | Screw hole diameter | 4.2 | 4.2 | 4.2 | 4.2 | 4.2 |
| | g | Usable thread length | 3 | 3 | 3 | 3 | 3 |
| | g ₁ | Clamping length | 2.2 | 2.2 | 2.2 | 2.2 | 2.2 |
| | | Ball diameter | 1 | 1 | 1 | 1 | 1 |
| | f ₃ | Distance to first through hole | 5.7 | 6 | 7 | 15 | 15 |
| | f ₄ | Spacing of through hole | - | 28 | 36 | 30 | 40 |
| | f ₅ | Lateral spacing of through hole | 8.5 | 8.5 | 8.5 | 8.5 | 8.5 |
| | s | Sensor Mid-point | 15 | 20 | 25 | 30 | 35 |
| | s ₁ | Spacing from sensor | 3.7 | 3.7 | 3.7 | 3.7 | 3.7 |
| | s ₂ | Sensor width | 5.4 | 5.4 | 5.4 | 5.4 | 5.4 |
| s ₃ | Sensor length | 13 | 13 | 13 | 13 | 13 | |
| s ₄ | Length of the sensor print | 75 | 75 | 75 | 75 | 75 | |
| r _{min} | Permissible bending radius | 2 | 2 | 2 | 2 | 2 | |
| Load capacity (N) | C ₀ | Static load capacity | 1193 | 1670 | 2148 | 2386 | 2864 |
| | C | Dynamic load capacity ($\approx C_{100}$) | 609 | 770 | 919 | 989 | 1124 |
| Torque (Nm) | M _{0L} | Permissible lateral static torque | 5.1 | 7.2 | 9.2 | 10.3 | 12.3 |
| | M _{0L} | Permissible static torque lengthwise | 5 | 8.6 | 13.1 | 15.8 | 21.8 |
| | M _d | Permissible lateral dynamic torque | 2.6 | 3.3 | 4 | 4.3 | 4.8 |
| | M _L | Permissible dynamic torque lengthwise | 2.5 | 4 | 5.6 | 6.5 | 8.5 |
| Weight (g) | | | 24.5 | 32.6 | 40.5 | 48.5 | 56.3 |

6 Dimension Tables, Load Capacities, Weights and Moment Loads

6.2 MSQS 9

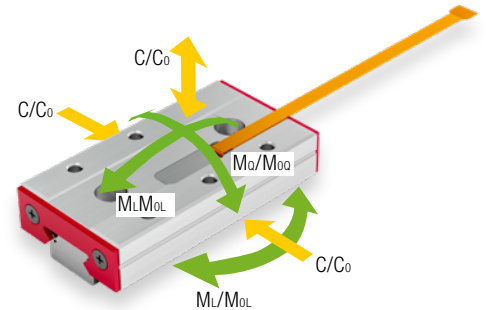
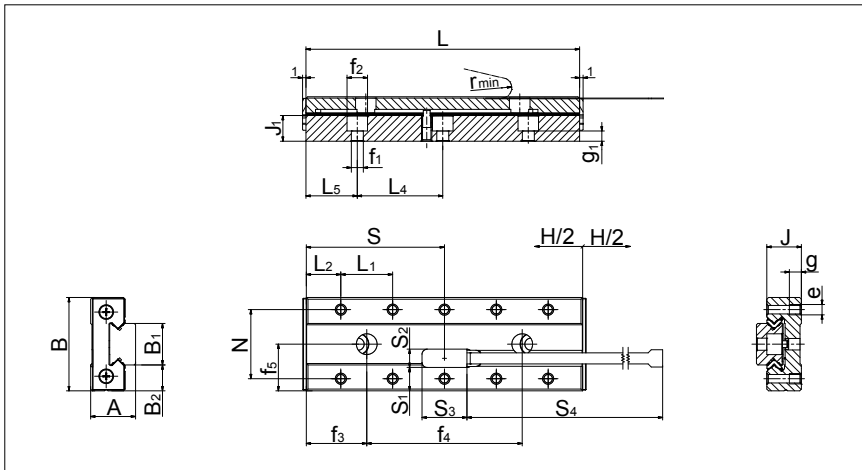

| Name | | Sizes | | | | | | |
|-----------------|-------------------|---------------------------------------|--|--------------|--------------|--------------|------|------|
| | | MSQS 9-40.34 | MSQS 9-50.42 | MSQS 9-60.50 | MSQS 9-70.58 | MSQS 9-80.66 | | |
| Dimensions (mm) | A | System height | 10 | 10 | 10 | 10 | 10 | |
| | B | System width | 20 | 20 | 20 | 20 | 20 | |
| | B ₁ | Rail width | 9 | 9 | 9 | 9 | 9 | |
| | B ₂ | Distance between locating surfaces | 5.5 | 5.5 | 5.5 | 5.5 | 5.5 | |
| | J | Carriage height | 8 | 8 | 8 | 8 | 8 | |
| | J ₁ | Rail height | 5.5 | 5.5 | 5.5 | 5.5 | 5.5 | |
| | H | Stroke | 34 | 42 | 50 | 58 | 66 | |
| | L | System length | 40 | 50 | 60 | 70 | 80 | |
| | L ₁ | Attachment hole spacing | 10 | 10 | 10 | 10 | 10 | |
| | L ₂ | Attachment hole start/end spacing | 10 | 10 | 10 | 10 | 10 | |
| | L ₄ | Attachment hole spacing | 20 | 20 | 20 | 20 | 20 | |
| | L ₅ | Attachment hole start/end spacing | 10 | 5 | 10 | 5 | 10 | |
| | N | Lateral attachment hole spacing | 15 | 15 | 15 | 15 | 15 | |
| | e | Thread | M3 | M3 | M3 | M3 | M3 | |
| | f ₁ | Attachment hole diameter | 3.5 | 3.5 | 3.5 | 3.5 | 3.5 | |
| | f ₂ | Screw hole diameter | 6 | 6 | 6 | 6 | 6 | |
| | g | Usable thread length | 3 | 3 | 3 | 3 | 3 | |
| | g ₁ | Clamping length | 2 | 2 | 2 | 2 | 2 | |
| | | Ball diameter | 1 | 1 | 1 | 1 | 1 | |
| | f ₃ | Distance to first through hole | 10 | 10 | 15 | 15 | 15 | |
| | f ₄ | Spacing of through hole | - | 30 | 30 | 40 | 50 | |
| | f ₅ | Lateral spacing of through hole | 10 | 10 | 10 | 10 | 10 | |
| | s | Sensor Mid-point | 20 | 25 | 30 | 35 | 40 | |
| | s ₁ | Spacing from sensor | 4.2 | 4.2 | 4.2 | 4.2 | 4.2 | |
| | s ₂ | Sensor width | 5.4 | 5.4 | 5.4 | 5.4 | 5.4 | |
| | s ₃ | Sensor length | 13 | 13 | 13 | 13 | 13 | |
| | s ₄ | Length of the sensor print | 75 | 75 | 75 | 75 | 75 | |
| | r _{min} | Permissible bending radius | 2 | 2 | 2 | 2 | 2 | |
| | Load capacity (N) | C ₀ | Static load capacity | 1432 | 1909 | 2386 | 2864 | 3341 |
| | | C | Dynamic load capacity ($\triangleq C_{100}$) | 692 | 846 | 989 | 1124 | 1252 |
| | Torque (Nm) | M ₀₀ | Permissible lateral static torque | 7.6 | 10.1 | 12.6 | 15.2 | 17.7 |
| M _{0L} | | Permissible static torque lengthwise | 6.7 | 10.8 | 15.8 | 21.8 | 28.7 | |
| M ₀ | | Permissible lateral dynamic torque | 3.7 | 4.5 | 5.2 | 6 | 6.6 | |
| M _L | | Permissible dynamic torque lengthwise | 3.2 | 4.8 | 6.5 | 8.5 | 10.7 | |
| Weight (g) | | | 45.6 | 56.9 | 68.1 | 79.2 | 90.3 | |

6 Dimension Tables, Load Capacities, Weights and Moment Loads

6.3 MSQS 12

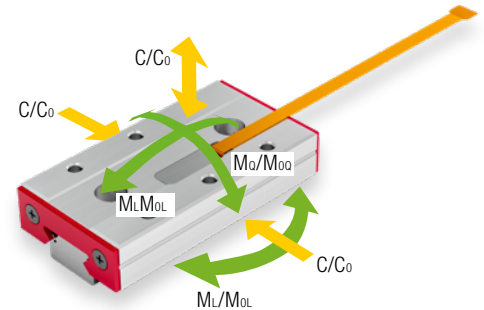
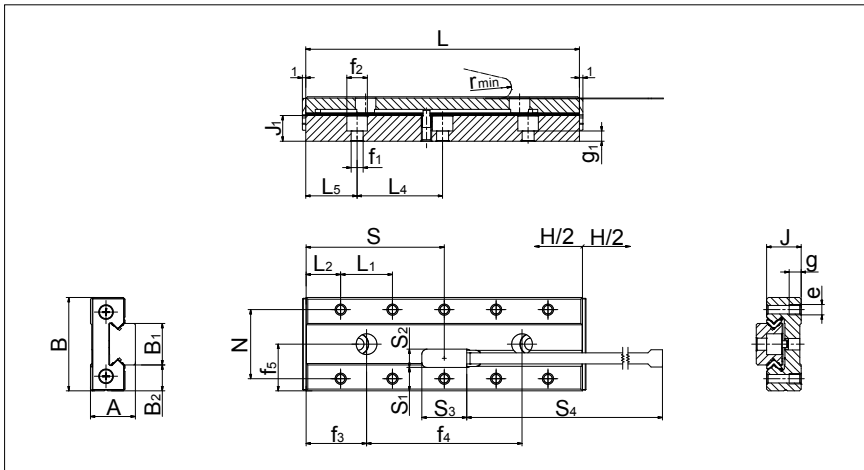

| Name | | Sizes | | | | |
|-------------------|----------------------------|---|---------------|---------------|----------------|-------|
| | | MSQS 12-50.45 | MSQS 12-60.48 | MSQS 12-80.63 | MSQS 12-100.70 | |
| Dimensions (mm) | A | System height | 13 | 13 | 13 | 13 |
| | B | System width | 27 | 27 | 27 | 27 |
| | B ₁ | Rail width | 12 | 12 | 12 | 12 |
| | B ₂ | Distance between locating surfaces | 7.5 | 7.5 | 7.5 | 7.5 |
| | J | Carriage height | 10 | 10 | 10 | 10 |
| | J ₁ | Rail height | 7.5 | 7.5 | 7.5 | 7.5 |
| | H | Stroke | 45 | 48 | 63 | 70 |
| | L | System length | 50 | 60 | 80 | 100 |
| | L ₁ | Attachment hole spacing | 15 | 15 | 15 | 15 |
| | L ₂ | Attachment hole start/end spacing | 10 | 7.5 | 10 | 12.5 |
| | L ₄ | Attachment hole spacing | 25 | 25 | 25 | 25 |
| | L ₅ | Attachment hole start/end spacing | 12.5 | 5 | 15 | 12.5 |
| | N | Lateral attachment hole spacing | 20 | 20 | 20 | 20 |
| | e | Thread | M3 | M3 | M3 | M3 |
| | f ₁ | Attachment hole diameter | 3.5 | 3.5 | 3.5 | 3.5 |
| | f ₂ | Screw hole diameter | 6 | 6 | 6 | 6 |
| | g | Usable thread length | 3.5 | 3.5 | 3.5 | 3.5 |
| | g ₁ | Clamping length | 3 | 3 | 3 | 3 |
| | | Ball diameter | 1.5 | 1.5 | 1.5 | 1.5 |
| | f ₃ | Distance to first through hole | 10 | 15 | 17.5 | 20 |
| | f ₄ | Spacing of through hole | 30 | 30 | 45 | 60 |
| | f ₅ | Lateral spacing of through hole | 13.5 | 13.5 | 13.5 | 13.5 |
| | s | Sensor Mid-point | 25 | 30 | 40 | 50 |
| | s ₁ | Spacing from sensor | 6.7 | 6.7 | 6.7 | 6.7 |
| | s ₂ | Sensor width | 5.4 | 5.4 | 5.4 | 5.4 |
| | s ₃ | Sensor length | 13 | 13 | 13 | 13 |
| | s ₄ | Length of the sensor print | 75 | 75 | 75 | 75 |
| r _{min} | Permissible bending radius | 2 | 2 | 2 | 2 | |
| Load capacity (N) | C ₀ | Static load capacity | 2685 | 3759 | 5370 | 7518 |
| | C | Dynamic load capacity ($\pm C_{100}$) | 1427 | 1806 | 2318 | 2934 |
| Torque (Nm) | M ₀₀ | Permissible lateral static torque | 18.9 | 26.5 | 37.9 | 53 |
| | M _{0L} | Permissible static torque lengthwise | 15.7 | 27 | 49.5 | 90.1 |
| | M ₀ | Permissible lateral dynamic torque | 10.1 | 12.7 | 16.3 | 20.7 |
| | M _L | Permissible dynamic torque lengthwise | 8.3 | 12.9 | 21.4 | 35.1 |
| Weight (g) | | | 103.9 | 124.4 | 165.5 | 206.5 |

6 Dimension Tables, Load Capacities, Weights and Moment Loads

6.4 MSQS 15

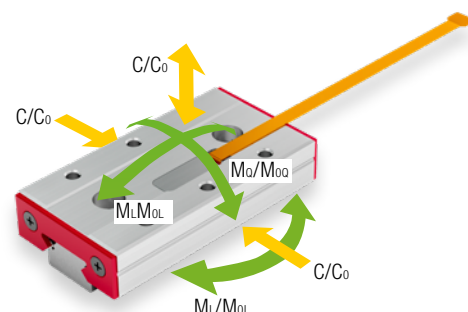
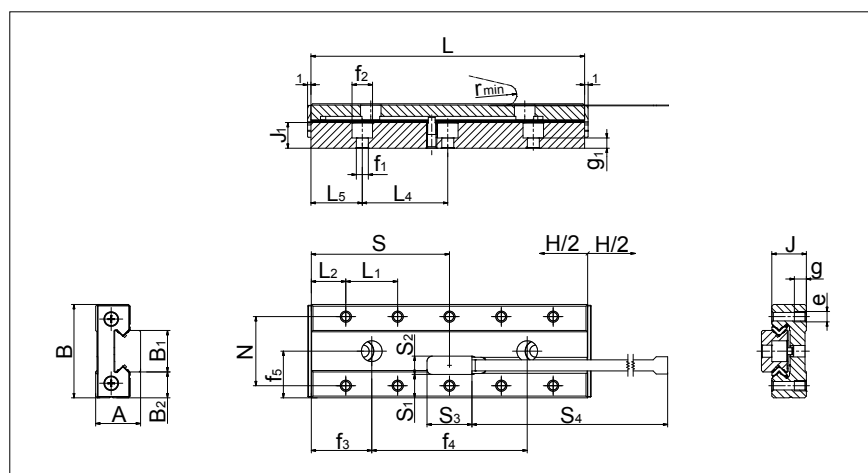

| Name | | Sizes | | | | | |
|-----------------|-------------------|---------------------------------------|--|----------------|-----------------|-------|-------|
| | | MSQS 15-70.66 | MSQS 15-90.70 | MSQS 15-110.96 | MSQS 15-130.102 | | |
| Dimensions (mm) | A | System height | 16 | 16 | 16 | 16 | |
| | B | System width | 32 | 32 | 32 | 32 | |
| | B ₁ | Rail width | 15 | 15 | 15 | 15 | |
| | B ₂ | Distance between locating surfaces | 8.5 | 8.5 | 8.5 | 8.5 | |
| | J | Carriage height | 12 | 12 | 12 | 12 | |
| | J ₁ | Rail height | 9.5 | 9.5 | 9.5 | 9.5 | |
| | H | Stroke | 66 | 70 | 96 | 102 | |
| | L | System length | 70 | 90 | 110 | 130 | |
| | L ₁ | Attachment hole spacing | 20 | 20 | 20 | 20 | |
| | L ₂ | Attachment hole start/end spacing | 15 | 15 | 15 | 15 | |
| | L ₄ | Attachment hole spacing | 40 | 40 | 40 | 40 | |
| | L ₅ | Attachment hole start/end spacing | 15 | 5 | 15 | 5 | |
| | N | Lateral attachment hole spacing | 25 | 25 | 25 | 25 | |
| | e | Thread | M3 | M3 | M3 | M3 | |
| | f ₁ | Attachment hole diameter | 3.5 | 3.5 | 3.5 | 3.5 | |
| | f ₂ | Screw hole diameter | 6 | 6 | 6 | 6 | |
| | g | Usable thread length | 4 | 4 | 4 | 4 | |
| | g ₁ | Clamping length | 5 | 5 | 5 | 5 | |
| | | Ball diameter | 2 | 2 | 2 | 2 | |
| | f ₃ | Distance to first through hole | 15 | 25 | 25 | 25 | |
| | f ₄ | Spacing of through hole | 40 | 40 | 60 | 80 | |
| | f ₅ | Lateral spacing of through hole | 16 | 16 | 16 | 16 | |
| | s | Sensor Mid-point | 35 | 45 | 55 | 65 | |
| | s ₁ | Spacing from sensor | 8.3 | 8.3 | 8.3 | 8.3 | |
| | s ₂ | Sensor width | 5.4 | 5.4 | 5.4 | 5.4 | |
| | s ₃ | Sensor length | 13 | 13 | 13 | 13 | |
| | s ₄ | Length of the sensor print | 75 | 75 | 75 | 75 | |
| | r _{min} | Permissible bending radius | 2 | 2 | 2 | 2 | |
| | Load capacity (N) | C ₀ | Static load capacity | 4773 | 7637 | 8592 | 11456 |
| | | C | Dynamic load capacity ($\triangleq C_{100}$) | 2611 | 3628 | 3940 | 4820 |
| | Torque (Nm) | M ₀₀ | Permissible lateral static torque | 42.5 | 68 | 76.5 | 102 |
| M _{0L} | | Permissible static torque lengthwise | 36.7 | 80.9 | 99.5 | 166.6 | |
| M ₀ | | Permissible lateral dynamic torque | 23.2 | 32.3 | 35.1 | 42.9 | |
| M _L | | Permissible dynamic torque lengthwise | 20.1 | 38.4 | 45.6 | 70.1 | |
| Weight (g) | | | 216.2 | 277.5 | 338.6 | 399.5 | |

7 Load Carrying Capacity and Service Life

7.1 Principles

The load capacities are based on the principles of DIN 636.

In accordance with DIN in most applications a permanent overall deformation of 0.0001 times the rolling element diameter can be permitted without adversely affecting the operating behaviour of the bearing. Consequently, the static load capacity C_0 is set sufficiently high that the aforementioned deformation occurs approximately when the equivalent static load corresponds to the static load capacity. Being guided by the dynamic load capacity C is recommended so that the aforementioned overall deformation does not occur.

The dynamic load capacity C is the load at which a nominal service life L of 100 km of travel distance is achieved. It is important to note when calculating the service life that not only the load, which acts vertically on the guideway, should be taken into account but also the load spectrum of all acting forces and moments.

The service life corresponds to the total travel distance in meters which a guideway facilitates. And this is before any noticeable material fatigue on one of the roller guideway elements. The nominal service life is achieved when 90% of the guideways of identical construction reach or exceed the corresponding travel distances under normal operating conditions.

Critical for the dimensioning of the guideways are the loads occurring proportionally with the dynamic load capacity C .

The dynamic load capacity C as given in the catalog corresponds to (\triangleq) the definition of C_{100} .

Definition of service life

As previously mentioned, the dynamic load capacity C_{100} is based on a service life of 100 km. Other manufacturers frequently indicate the load capacity C_{50} for a service life of 50 km. The resulting load capacities from this are more than 20% higher than specified by the DIN ISO standard.

Conversion example for ball bearings

Convert C_{50} load capacities to C_{100} in accordance with the DIN ISO standard:

$$C_{100} = 0.79 \cdot C_{50}$$

Convert C_{100} load capacities to C_{50} :

$$C_{50} = 1.26 \cdot C_{100}$$

C_{50} = dynamic load capacity C in N for 50 km of travel distance
 C_{100} = dynamic load capacity C in N for 100 km of travel distance, defined in accordance with DIN ISO standard

7 Load Carrying Capacity and Service Life

7.2 Calculation of Service Life L in Accordance with the DIN ISO Standard

7.2.1. The Formula for Calculating the Nominal Service Life for Ball Guideways in Meters is as follows:

$$L = a \cdot \left(\frac{C_{\text{eff}}}{P} \right)^3 \cdot 10^5 \text{ m}$$

a = Event probability factor
 C_{eff} = Effective load carrying capacity N
 P = Dynamic, equivalent load in N
 L = Nominal service life in m

Event probability factor a

The load carrying capacities for roller-contact bearings correspond to the DIN ISO standard. This represents a value from the service life calculation, which has a 90% chance of being exceeded during operational use of the guideway.

If the previously mentioned theoretical service life probability factor of 90% is not sufficient, the service life values will need to be adjusted by a factor a.

| | | | | | | |
|------------------------|----|------|------|------|------|------|
| Event probability in % | 90 | 95 | 96 | 97 | 98 | 99 |
| Factor a | 1 | 0.62 | 0.53 | 0.44 | 0.33 | 0.21 |

7.2.2. The Formula for Calculating Nominal Service Life in Hours is as follows:

$$L_h = \frac{L}{2 \cdot s \cdot n \cdot 60} = \frac{L}{60 \cdot v_m}$$

L = Nominal service life in m
 L_h = Nominal service life in h
 s = Stroke length in m
 n = Stroke frequency in min⁻¹
 v_m = Medium travelling speed in m/min

7.2.3. Effective Load Carrying Capacity C_{eff}

Constructive and external influences can reduce the dynamic load capacity C of MINI-X products in such a way that C_{eff} must be calculated.

$$C_{\text{eff}} = f_K \cdot C$$

C_{eff} = Effective load carrying capacity N
 f_K = Contact factor
 C = Maximum permissible dynamic load carrying capacity in N

7 Load Carrying Capacity and Service Life

Contact factor f_k

If multiple carriages are mounted back-to-back with minimal spacing ($L_b < L$), an even weight distribution will be difficult to achieve due to the manufacturing tolerances of the guideway elements and mounting surfaces. Installation situations such as these can be allowed for with the contact factor f_k :

| | | | | | |
|----------------------|---|------|------|------|------|
| Number of carriages | 1 | 2 | 3 | 4 | 5 |
| Contact factor f_k | 1 | 0.81 | 0.72 | 0.66 | 0.62 |

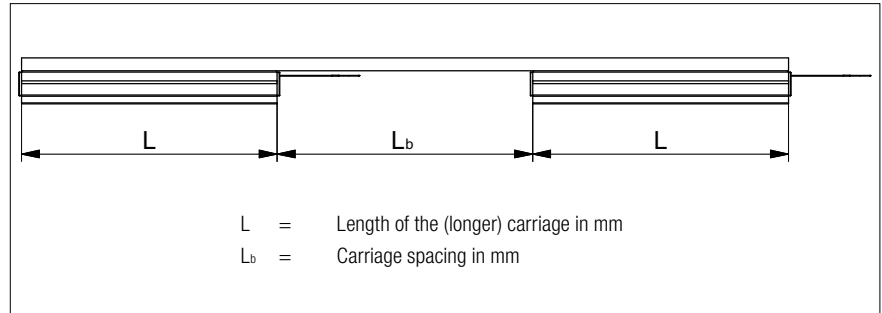

7.2.4. Dynamically Equivalent Load P

The loads (F) acting on a linear guideway system are subject to frequent fluctuations during operation. This set of circumstances should be taken into account when calculating service life. The varying load absorption of the guideway at varying operating conditions during the travel distance is described as being the dynamic equivalent load P .

$$P = \sqrt[3]{\frac{1}{L}(F_1^3 \cdot L_1 + F_2^3 \cdot L_2 + \dots + F_n^3 \cdot L_n)}$$

Stepped load

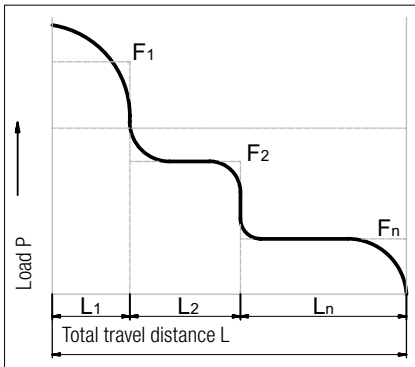

Sinusoidal load

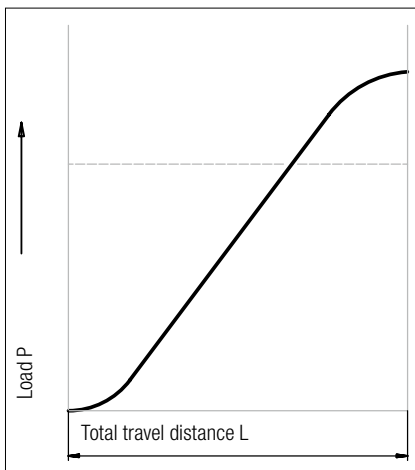

$$P = 0.7 F_{max}$$

- P = Equivalent load in N
- $F_1 \dots F_n$ = Individual load in N during the partial travel distance $L \dots L_n$
- F_{max} = Max. load in N
- L = $L_1 + \dots + L_n$ = Total travel during one load cycle in mm
- $L_1 \dots L_n$ = Partial travel distance in mm of one individual load during a load cycle

8 Ordering Information

Order designation:

| Ordering sequence | | 100 | MSQ-Scale | 7- | 30. | 20- | A- | MG- | 0.1- | RS- | SB- | SH- | HA- | KB |
|-------------------------------|--------------------|-----|-----------|----|-----|-----|----|-----|------|-----|-----|-----|-----|----|
| Quantity | | | | | | | | | | | | | | |
| Series | MSQS | | | | | | | | | | | | | |
| Rail width B ₁ | in mm | | | | | | | | | | | | | |
| Rail length L | in mm | | | | | | | | | | | | | |
| Stroke H | in mm | | | | | | | | | | | | | |
| Analog oder Digital | A, D | | | | | | | | | | | | | |
| Interface module | MG, OG, NL, MM, KI | | | | | | | | | | | | | |
| Resolution [µm] | 0.1, 1, 10 | | | | | | | | | | | | | |
| Special Reference mark | RS | | | | | | | | | | | | | |
| Special Drilling pattern | SB | | | | | | | | | | | | | |
| Special Stroke ⁽¹⁾ | SH | | | | | | | | | | | | | |
| Height-matched | HA | | | | | | | | | | | | | |
| Customer-specific lubrication | KB | | | | | | | | | | | | | |

Legend:

| | | | |
|----|-------------------------|----|-------------------------------|
| A | Analog | KI | Without Interface modul |
| D | Digital | RS | Special Reference mark |
| MG | With housing (Standard) | SB | Special Drilling pattern |
| OG | Without housing | SH | Special Stroke ⁽¹⁾ |
| NL | Only circuit board | HA | Height-matched |
| MM | Micro Match | KB | Customer-specific lubrication |

⁽¹⁾ The SH option shortens the stroke according to customer's request and at the same time lengthens the cage to the maximum to enable highest possible loads.

Options:

The options must be ordered separately:

| Order number | Article |
|--------------|--|
| 556 100 151 | Base plate |
| 556 100 152 | Clamp plate |
| 556 100 160 | FFC extension cable 250 mm including Adapter |
| 556 100 161 | FFC extension cable 400 mm including Adapter |
| 556 100 162 | FFC extension cable 600 mm including Adapter |

www.schneeberger.com

www.schneeberger.com/contact

PROSPECTUSES

- CUSTOMIZED BEARINGS
- GEAR RACKS
- LINEAR BEARINGS AND RECIRCULATING UNITS
- MINERAL CASTING SCHNEEBERGER
- MINISLIDE MSQSCALE
- MINI-X MINIRAIL / MINISCALE PLUS / MINISLIDE
- MONORAIL AND AMS PROFILED LINEAR GUIDEWAYS WITH INTEGRATED MEASURING SYSTEM
- MONORAIL AND AMS APPLICATION CATALOG
- POSITIONING SYSTEMS
- SLIDES

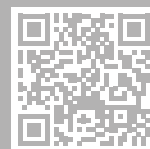

www.schneeberger.com

www.schneeberger.com